

THIS DRAWING IS UNPUBLISHED. RELEASED FOR PUBLICATION
 © COPYRIGHT 19 BY AMP INCORPORATED. ALL INTERNATIONAL RIGHTS RESERVED.

LOC	DIST	P	F	ZONE	LTR	DESCRIPTION	DATE	APPD
AJ	16					O REL PER PR 92-3386-100	13/JUL/93	BMW
						A REV PER 0220-0218-93	28/OCT/93	BMW
						B REV PER 0220-0401-93	11/JAN/94	BMW
						C REVISED PER 0503-0860-97	2-12-98	JG
						D REVISED PER 0630-0096-98	3-18-98	JG

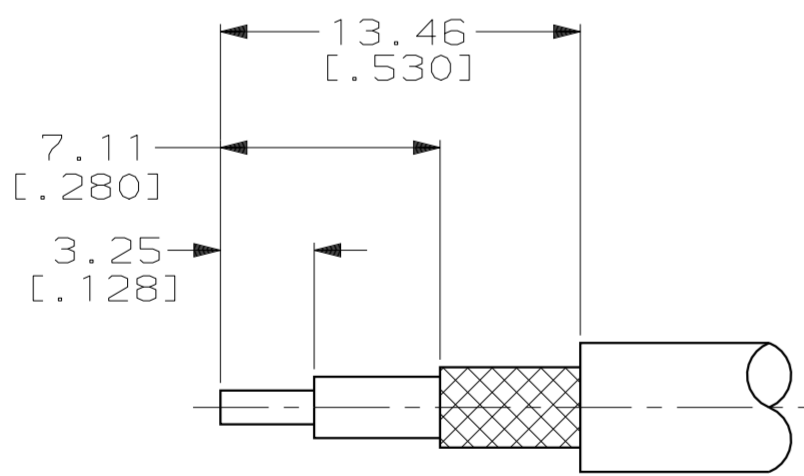
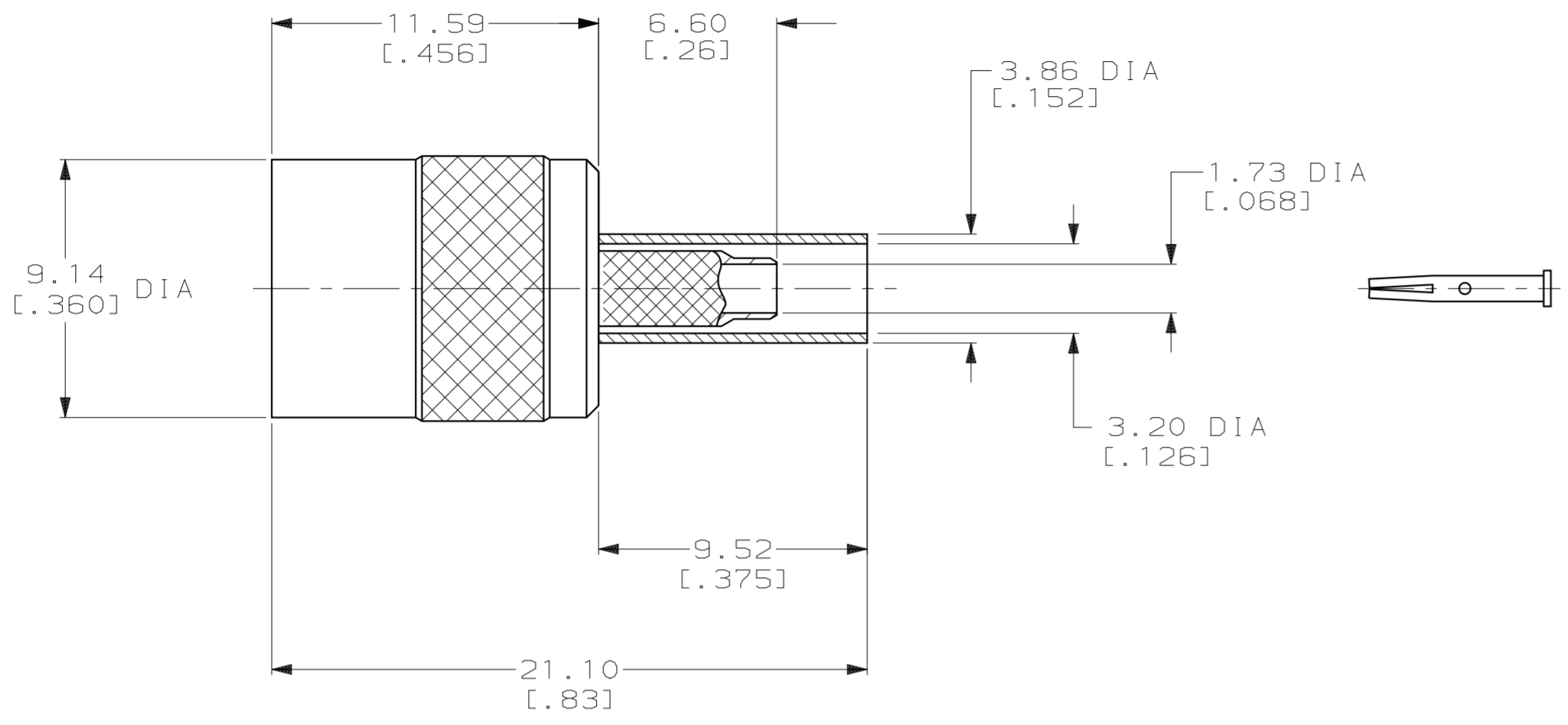

1. MATERIALS:
 BODIES...BRASS PER QQ-B-626
 INNER AND OUTER CONTACTS...
 BERYLLIUM COPPER PER QQ-C-576
 DIELECTRIC...TEFLON PER ASTM D1710
 FERRULE...ANNEALED COPPER PER QQ-C-576
2. FINISH:
 CENTER CONTACT...GOLD PER MIL-G-45204
 OTHER METAL PARTS...NICKEL PER QQ-N-290
3. FINISH:
 CENTER AND OUTER CONTACT...GOLD PER MIL-G-45204
 OTHER METAL PARTS...NICKEL PER QQ-N-290

POSITION LETTER	AMP DIE SET	HEX SIZE	DANIELS DIE SET	SELECTOR NUMBER	DANIELS POSITIONER	NOTES	CABLE	PART NUMBER
B	58483-1	.128	HX4-1637	4	K699	2	RG 179,187	414618-2
B	58483-1	.128	HX4-1637	4	K699	3	RG 179,187	414618-1
AMP PRO-CRIMPER FOR BRAID CRIMP						M 22520/5-01 FOR BRAID CRIMP		
AMP PRO-CRIMPER FOR BRAID CRIMP						M 22520/2-01 FOR CONTACT CRIMP		

TOOLING INFORMATION

RECOMMENDED STRIP LENGTHS
 SCALE NTS

DO NOT SCALE PRINT. UNLESS SPECIFIED DIMENSIONS IN mm [INCHES]		PART NO	
TOLERANCES ON :		AMP Incorporated Harrisburg, PA 17105-3608	
2 PLC DEC ± .25 [.010]		NAME	
3 PLC DEC ± .13 [.005]		75 OHM SMB PLUG	
ANGLES ± -		SIZE CAGE CODE DRAWING NO	
MATERIAL		C 00779 C= 414618	
SEE NOTES		SCALE 5:1 SHEET 1 OF 1	
FINISH		APPLICATION SPEC	
SEE NOTES		-	
WEIGHT		-	

THIS DRAWING IS A CONTROLLED DOCUMENT FOR AMP INCORPORATED. IT IS SUBJECT TO CHANGE AND THE CONTROLLING ENGINEERING ORGANIZATION SHOULD BE CONTACTED FOR THE LATEST REVISION.